

## Performance Improvement of Multi-type Batteries for Electric Vehicles Using Python Programming

Dr. K. Dhananjaya Babu<sup>a</sup>, B.Poli Reddy, K. Siva Kumar<sup>\*</sup>, K. Naveen Kumar, and B. Naveen Kumar Reddy

<sup>a</sup>Department of EEE, Annamacharya Institute of Technology and Sciences, Rajampet-516126

<sup>\*</sup>kuppamsivakumar77@gmail.com

**Abstract**— In recent times, Electric Vehicle for domestic transportation has seen a significant increase. As per Federation of Automobile Dealers Association-sourced industry statistics, retail sales of EVs there is a 218% increase in FY2022 when compared with previous year. The EV has different and some crucial component which decide the functioning of EVs efficiently, of which Batteries are the most significant ones. It is conventional to use batteries manufactured from single source material. Batteries account for 29% of Electric vehicle density. So reducing the weight of the battery would actually increase the efficiency of the vehicle in performance and occupancy of the passengers for the same ratings of the drive. In this project it is aimed to use Multi-type batteries for EVs, which have different weight densities. In this work when batteries of different density were used the drive setting were undisturbed. The problem associated with multi-type batteries is that temperature has to be maintained and necessary counter cooling techniques should be needed. The result of the project is focused on the batteries parameters control for having the desired performance

### 1. introduction

In 1996, General Motors unveiled the EV1, an all-electric car powered by a heavy lead-acid battery. The EV1 was enthusiastically received, but a host of economic, regulatory, and technical concerns prompted GM to discontinue the car's leasing program in 2002. Instead of ushering in an era of electric cars, the EV1 was widely seen as a disappointment.

But now, thanks, in part, to major improvements in battery technology, electric vehicles are having their day in the sun. Later this year, GM will begin selling the Chevrolet Volt, a plug-in hybrid, and Nissan will begin selling the Leaf, an all-electric passenger car with a 100-mile range. In May, Tesla Motors purchased a former Toyota plant in Fremont, Calif., to begin manufacturing its all-electric Model S sedans.

Many countries are looking toward electric vehicles for the benefits they offer in terms of energy security and the environment. Cutting the demand for gasoline would help reduce dependence on imported oil, shifting that demand to domestic electricity production. Whether electric vehicles will help reduce greenhouse gases depends on where their electric power comes from—fossil fuels or renewable sources—a mix that varies from one country to another. What will it take to get widespread adoption of plug-in hybrids and all-electric cars? For consumers, battery-powered cars need to have a range long enough to accommodate the average commute, reasonable recharging time, and affordable cost. Continued improvements in battery technology, as well as development of an infrastructure of recharging stations, are crucial to satisfy all these demands.

Today's hybrids, such as the Toyota Prius use nickel-metal hydride batteries, but the cars now emerging feature lithium-ion ones. The transition to lithium-ion has been driven by the differences in power needs between hybrids

and plug-in hybrids. Hybrid electric vehicles (HEVs) are propelled by both than internal combustion engine and a battery that is used as a power assist; it kicks in when the engine is least efficient, such as during idling or acceleration and deceleration. Because the battery gets recharged by regenerative braking, the driver only needs to refill the gas tank, just as with a traditional car.

In a plug-in hybrid (PHEV), such as the Chevrolet Volt, the battery powers the drive train, while the internal combustion engine serves as a backup in case the battery gets depleted on the road. The driver plugs in the car to recharge the battery, a process that can take several hours. All-electric vehicles, also known as battery electric vehicles (BEVs), such as the Nissan leaf, operate purely on battery charge.

## **2. Different Types Batteries**

In this paper mainly concentrating two types batteries that is two three cases are occurring they are given below

1. individual li-ion battery
2. individual li-polymer battery
3. both the li-ion & li-polymer

### **Case 1. li-ion battery analysis**

The upsides of lithium-particle batteries for vehicle applications are their light weight, high energy thickness, absence of memory impact, and capacity to be reused. Lithium-particle batteries are currently generally utilized in convenient purchaser contraptions. Be that as it may, a vehicle puts fundamentally more noteworthy expectations on a lithium-particle battery than a telephone or PC do. A battery for a module half and half electric vehicle (PHEV) with a 40-mile reach ought to have the option to endure 5,000 charging cycles, most recent 15 years at 35°C, gauge something like 120 kg, and cost \$3,400 at greatest creation, as indicated by the U.S. High level Battery Consortium, whose individuals incorporate Chrysler, Passage, and GM (100,000 units for every year). "No battery meets the entirety of the mass and volume objectives today," said Imprint Verburgge, overseer of the Materials and Cycles Lab at the General Engines Innovative work Community in Warren, Mich. Progresses in the materials utilized in the cathode, anode, and electrolyte have assisted with working on the presentation and lower the expense of lithium-particle batteries. Cathodes in traditional lithium-particle batteries are made of lithium cobalt oxide (LiCoO<sub>2</sub>), however because of wellbeing concerns, specialists have moved towards involving different materials in vehicle batteries.

### **Case 2. li-polymer battery analysis**

The lithium polymer battery cell researched is ostensibly evaluated at 3.7 volts and 100 Ah. A power rating couldn't be as determined. The battery estimates 0.72cm thickness, 45.5cm width, and 32.5cm length for a volume of 1.065 liters. The battery has a mass of 2.7kg. This compares to a particular energy of 146 W-h/kg, and an evaluated energy thickness of 373 Wh/L. These evaluations will be surveyed and the power limit will be laid out [5]. The battery duration cycle is assessed by the producer to be more than 1200 cycles with 80% of profundity of release. The lithium battery has a low self release pace of roughly 5% each month, contrasted and more than 30% each month in

nickel metal hydride battery, and 20% each month in nickel cadmium batteries

The lithium polymer battery utilizes lithium cobalt dioxide as the positive terminal and an exceptionally solidified specialty carbon at the negative cathode. The two responses are interceded by electrolyte. Fluid electrolyte in lithium polymer battery comprise of LiPF<sub>6</sub> (Lithium Hexafluorophosphate) and natural solvents.

**Case 3.li-ion +li-polymer**

The li-ion battery and li-polymer batteries both combining the by using the Pybamm software in this software plotting the graphs. Two batteries are connecting by using switches according to requirement they connected series or parallel.

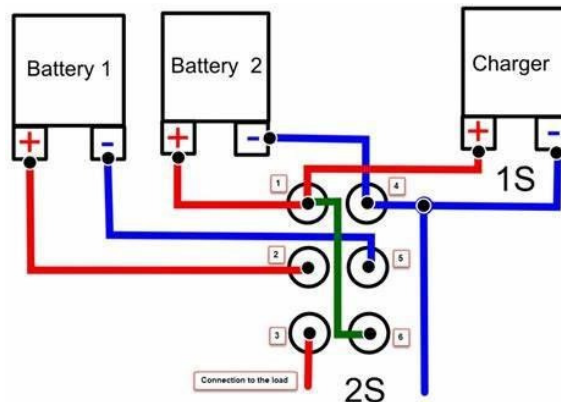

**Fig: connection diagram of both batteries**

**2.BaTTERY MANAGEMENT SYSTEM**

Battery The executives Framework (BMS) is essentially battery observing which continues to keep an eye on the critical functional boundaries during charging and releasing like voltages, flows, and temperatures (interior and encompassing). The BMS typically gives contributions to assurance gadgets which produce cautions or disengage the battery from the heap or charger when any of the boundaries become out of cutoff points. The significant targets of BMS are [13,14]: (1) to safeguard the cells or the battery from harm; (2) to drag out the existence of the battery; and (3) to keep up with the battery in a state wherein it can satisfy the utilitarian prerequisites of the application for which it was determined. In this manner, the BMS might consolidate at least one of the accompanying capabilities: cell assurance, charge control, request the executives, condition of charge (SOC) assurance, condition of wellbeing (SOH) assurance, cell adjusting, correspondence, and so forth.

Fig. 2(a) shows the BMS which was created in the past review [1]. The SOC of every cell can be observed by a BIM (Battery Interconnect Supervisor), as displayed in Fig. 2(b), and each BIM is told by the BWM (Battery Module Administrator), as displayed in Fig. 2(c), to speak with its next neighbor BIM through a correspondence transport [15]. Once cheating or over-releasing of a cell happens, the BIM reports to its regulated BWM and self-cleanse to keep up with the wellbeing of the framework. The BIM arrangement gives exceptionally simple point of interaction its neighbors and proposition the remarkable component of attachment and-play

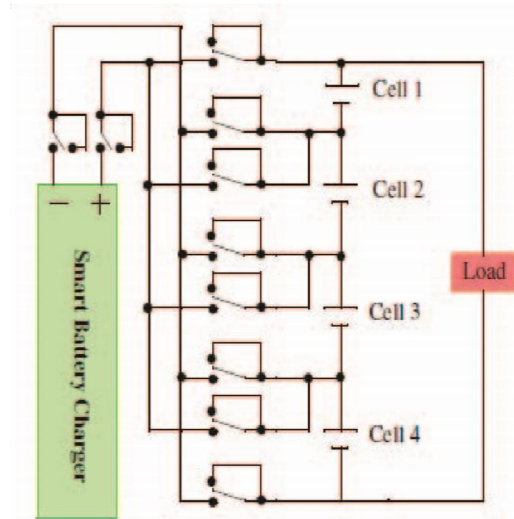

Fig. 1 Conventional Battery Pack for Balancing

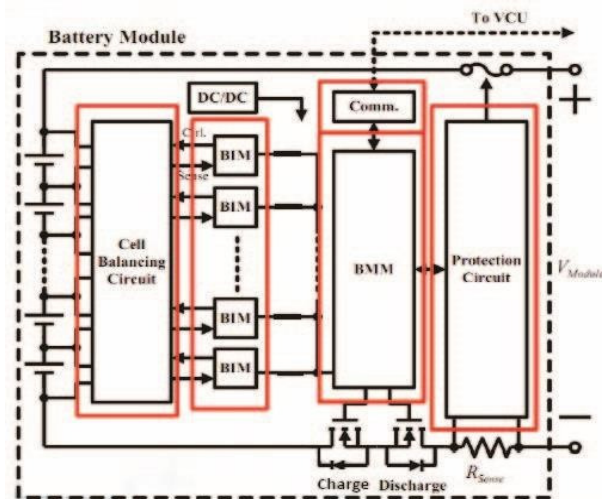

Fig: block diagram of battery module

### 3. pybamm software

PYBAMM delivers enhanced research impact and collaboration in battery By offering a modular framework through which existing or new tools can be coupled, continuum models for batteries can be solved. For instance, it is simple to modify PYBAMM to include additional models, other partial discretization, or different time-stepping algorithms. Any such additions can then be used right away with the existing set of models that have already been built, and comparisons between various models, discretizations, or algorithms can be made while holding variables like hardware, software, and implementation specifics constant. Similarly, new physics can be incorporated into existing models without having to start from scratch to investigate each new effect. This allows for the simultaneous investigation of a variety of extensions to standard battery models, such as coupling together several degradation mechanisms. PYBAMM is a key component of the Faraday Institution's 'Common Modeling Framework,' which is

part of the Multi-Scale Modeling Fast Start project and will serve as a central repository for UK battery modelling research. PYBAMM has already been used to develop and compare reduced-order models for lithium-ion and lead-acid batteries, and the results of future research are promising. Three case programs are provided.

#### Installation of PYBAMM

- Prerequisites
- Pybamm install
- User install
- Pybamm uninstall
- Installation using WSL

#### Prerequisites

Python 3.8 or 3.9 is required to use and/or contribute to PyBaMM.

To install Python 3, go to the Python website and download the installation files.

Check the box next to Add Python 3.X to PATH. Please see the official Python on Windows guide for more information.

#### Userinstall

Open Command Prompt and navigate to the directory where you want to install PyBaMM. A reminder of how to use the terminal can be found here. We recommend installing PyBaMM in a virtual environment to avoid modifying any distribution Python files.

To install virtualenv type:

For an introduction to virtual environments, see (<https://realpython.com/python-virtual-environments-a-primer/>).

To build a virtual environment env within your current directory, use the following syntax:

```
python-mvirtualenv env
```

The environment can then be "activated" using

```
env\Scripts\activate.bat
```

PyBaMM and its dependencies will now be installed into the environment env by all of the pip functions outlined below. Just type "exit" to leave the environment and return to your default system when you're ready.

PYBAMM is installable using pip:

```
pip install pybamm
```

When you install PyBaMM via pip, all of its dependencies (such as numpy, scipy, etc.) will be installed automatically.

#### Installation using WSL

---

If you want to install the optional PyBaMM solvers, you must use the Windows Subsystem for Linux (WSL). The installation instructions are available

## CONCLUSION

in this paper three cases are were considered for performance analysis of the batteries .among all cases , case.3 were li-ion and li-polymer batteries of are taken as combo to analyze the performance of battery through parameters like voltage ,current, capacity ,charging and discharging . for modeling pybamm tool is used and result obtained show that the combination of employing two types of batteries give result which are promising.

## 4. Feature research

- ❖ Two different batteries are using this paper one is li-ion and li-polymer.
- ❖ One battery is fully charged by the grid
- ❖ This charged battery is given to the power supply to the motor of electric vehicle now the EV is running condition
- ❖ By applying the regenerative braking to the EV charge the battery.
- ❖ And another method is the on top of the electric vehicle arrange the solar panels and it is renewable energy using this energy charge the battery in running condition.

## *Referances*

- [1.]BatterymanagementsystemAUnitizedChargingandDischargingSmartBatteryManagement SystemChin-LongWeyandPingChangJul
- [2.]C.-C.Wang,C.L.Wey,andP.- C.Jui,“DevelopmentofSmartBatteryManagementSystems,”Project Report, Sponsored by Department of Industrial Technology, Ministry of EconomicAffairs(MOEA),Taiwan,May2010.
- [3.]T.Sasaki, Y.UkyoandP. Novák, "Memoryeffectinalithium-ionbattery", NatureMaterials. Pythonprogrammingusing
- [4.][https://www.researchgate.net/publication/361398501\\_E-Vehicle\\_modelling\\_with\\_python\\_programming\\_language](https://www.researchgate.net/publication/361398501_E-Vehicle_modelling_with_python_programming_language)
- [5.]M.J.Riezenman,“TheSearchforBetterBatteries,”IEEESpectrum,v.32,pp.51-56,May2002
- [6.]“Lithium-IonBattery”,CleanEnergyInstitute.Retrieved6January2022.

