

The performance and emission evaluating of Diesel Engine by using alloys of copper and bronze coated & non-coated materials

M.Srinivasnaik¹, B. Kavitha², D Srinivas³ Srinivas Banothu⁴, S.Raju⁵.

¹Associate Professor in the Department of Mechanical Engineering Chaitanya Deemed to be University Warangal

²Lecturer in mechanical engineering, Government polytechnic Warangal,

³Senior Lecturer in Mechanical, S.G.Govt.Polytechnic Adilabad

⁴Lecturer in Mechanical Engineering, Govt.Polytechnic,Kataram, Jayashanker Bhupalapally District

⁵Assistant Professor in the Department of Mechanical Engineering Chaitanya Deemed to be University Warangal

ABSTRACT: A piston is a component of C.I engines, reciprocating pumps, gas compressors and pneumatic cylinders, among other similar mechanisms. It is the moving component that is contained by a cylinder and is made gas-tight by piston rings. The piston transforms the energy of the expanding gases into mechanical energy. The piston rides in the cylinder liner or sleeve. The main aim of the project is to design a piston with crown for C.I engine for two materials COPPER and BRONZE Alloy as coated and non-coated materials. The designs of the piston are modeled using CATIA software. The designs are evaluated Study state thermal analysis by applying temperatures. The result is evaluated by checking the heat thermal flux and temperature to decide the best performance of the piston with crown. Thermal analysis is done in ANSYS software.

Keywords: piston with crown, Copper and Bronze alloys, heat flux, temperature Thermal analysis, ANSYS software.

Introduction:

The piston changes the vitality of the growing gasses into mechanical vitality. The piston rides in the barrel liner, then again sleeve. Pistons are normally made of aluminum composites or press. To keep the ignition gasses from bypassing piston and to keep rubbing to a base, every piston has few metal rings around it. These rings work as the seal the piston and the barrel divider and furthermore act to erosion by limiting the contact as a rule 2 to 5, with ring playing out a particular capacity. The best ring(s) acts as the weight seal. The middle of the road ring(s) acts a wiper ring to expel and control the measure of oil film the chamber dividers. The base ring(s) is an oiler ring and that a supply of greasing up oil is equally kept on barrel dividers. Region between the piston and the barrel . The rings are typically made of solid metal and covered with or molybdenum. Most diesel motor pistons have few rings. Pistons climb and down in the

chambers apply a power on a liquid inside the barrel. Pistons have rings which serve to keep the oil out of the burning and the fuel and let some circulation into of the oil. Generally in a barrel have piston rings. For the most part there are two -pressure rings that go about as a seal between the piston, the barrel divider, and at least one oil control ring s the pressure rings. The leader of the piston can be, swell or generally molded. Pistons can be manufactured or the state of the piston is regularly adjusted yet can be. An exceptional sort of cast piston is the hypereutectic.[1, 2]

In the present numerical simulation work Pro-E, a modeling tool has been employed for modeling the piston. The developed model of the piston is saved in required format and imported in ANSYS for conducting the finite element analysis. The aim of the paper is to investigate the Al Si alloy piston temperature distribution by using different coating materials to achieve higher engine performance. Analyses have been performed for un-coated piston crown and ceramic-coated piston crown with a coat thickness of 0.3mm. The coating consists of 0.1mm bond coat copper and bronze and which are deposited onto the piston crown. Some of the properties of the ceramic coated inter layer metallic bond coat, rings and piston are listed. The bond coat layer is a copper and bronze alloy used between the thermal barrier coating and the metal substrate provides oxidation resistance and the internal stress resistance at higher temperatures helps in the bonding of the TBC layer to the substrate material. [3, 4]

Objectives:

1. To know the preparation of C.I ENGINE PISTON.
2. To study the applications of C.I ENGINE PISTON.
3. To understand the properties such as mechanical, electrical and thermal properties of coated and Non-Coated alloys.
4. To study the usage of coated and Non-Coated alloys

Literature review:

A work on optimization of a piston has been done by [5]. They have considered a piston from a practical example which has been considered in the present work as a base model. Much work has been done on the design optimization with bare pistons as well as pistons with thermal barrier coating in recent years. [6] Described the stress distribution and thermal stresses of three different aluminum alloy pistons by using finite element method in the year of 2014. [7] Presented a structural analysis of the piston in 2012. He analyzed the piston by Pro-E software to improve and optimize the structure of the piston. [8] Analyzed the piston, which were consists of two steps. They were Designing and Analysis. [9] In 2013 investigated the thermal analyses on a conventional (uncoated) diesel piston. In 2012 [10] analyzed a piston by ANASYS software to get the deformation, thermal and stress distribution of the piston. [11] Worked on a piston of a two-stroke spark ignition internal combustion engine which had maximum power of 6.5 kW at

5500 RPM. They were Designing and Analysis. They used Aluminum 4032 alloy as the piston material. [12] Measured the stress and temperature distribution on the top surface of a piston. The structural model of the piston would be developed using CATIA V5 software. Then they imported the CAD model into the Hyper Mesh for geometry cleaning and meshing purpose. [13] described design analysis and optimization of hybrid Piston for 4 stroke single cylinder 10 HP (7.35 kW) diesel Engine. They used high strength cast steel for piston crown and light alloy like aluminum alloy for piston wall. Using FEM they investigated the stress distribution of piston and analyzed the actual engine condition during combustion process. To avoid the failure of the piston, the stresses due to combustion were considered. [14] replaced the steel components with aluminum components to reduce the weight. The strength of aluminum components was not enough compared to steel components. Therefore, they were taking the aluminum alloy because the aluminum alloy exhibits the strength like the steel. [15] compared the behavior of the combustion engine pistons which were made of different type of materials under thermal load. Geometrical model of the piston was developed by CAD software. The model was based on the actual engine piston of TATA MOTORS four stroke diesel engine. [16] investigated and analyzed the stress distribution of piston at actual engine condition. In their paper pressure analysis, thermal analysis and thermo-mechanical analysis of the piston was performed. For analyzed the piston they used operating gas pressure, temperature and material properties of piston as parameter. Piston was analyzed using boundary conditions, which includes pressure on piston head during working condition and temperature distribution from piston head to skirt. [17] designed a 5B.H. P diesel engine piston. They modeled the piston using Pro-E software. They used Cast Aluminum, Aluminum MMC and Brass as piston material. Structural analysis was done on the piston by applying the pressure to determine the strength of the piston using 3 materials. Thermal analysis was done to find out the temperature distributions, heat transfer rate of the piston. [18] illustrated design procedure for a piston for 4 stroke petrol engines for Hero bike. They analyzed by the comparison with original piston dimensions which was used in bike. They considered the combined effect of mechanical and thermal load while determining various dimensions of the piston. Since the coefficient of thermal expansion for aluminium is about 2.5 times that of cast iron, therefore, a greater clearance must be provided between the piston and the cylinder wall (than with cast iron piston) in order to prevent seizing of the piston when engine runs continuously under heavy loads. But if excessive clearance is allowed, then the piston will develop 'piston slap' while it is cold and- this tendency increases with wear. The less clearance between the piston and the Cylinder wall will lead to seizing of piston. [19] worked with the design and analysis of piston. Here the piston design, analysis and the manufacturing processes were studied. Purpose of the investigation was the measurement of piston transient temperature at various points on the piston, from cold start to steady condition and comparison with the results of finite element analysis. [20] designed a piston using CATIA V5R20 software. Complete design was imported to ANSYS 14.5 software and analyzed. Aluminum alloy was selected for structural and thermal analysis of piston. [21]

Materials and methods:

Copper alloys become stronger and more ductile as temperature goes down. They also retain excellent impact resistance to 20 K. These general characteristics have been revealed in tests on 15 copper alloys, including brasses, bronzes and commercially pure coppers. They were tested by the Cryogenics Div., National Bureau of Standards, for the copper and brass industry to check tensile strength, notch tensile strength, Young’s modulus, and impact properties at temperatures down to 4 K (-454 F). The information presented here is based on a report by R. P. Reed and R. P. Mikesell "Low Temperature Mechanical Properties Of Copper and Selected Copper Alloys," NBS Monograph 101, Institute for Materials Research, National Bureau of Standards, Boulder, Colorado 80302. UNS C95800 alloy is bronze alloy. Other types of bronze alloys include phosphor bronze, tin bronze, aluminum bronze, silicon bronze, architectural bronze and bronze. The datasheet given below provides an overview of UNS C95800 alloy.

Non coated piston Material as copper:

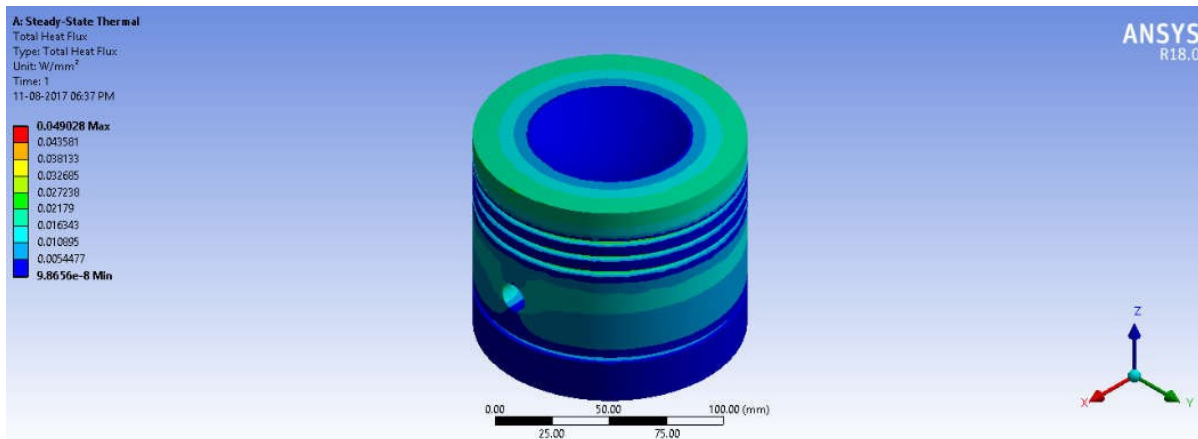

Figure 5 shows total heat flux piston with COPPER

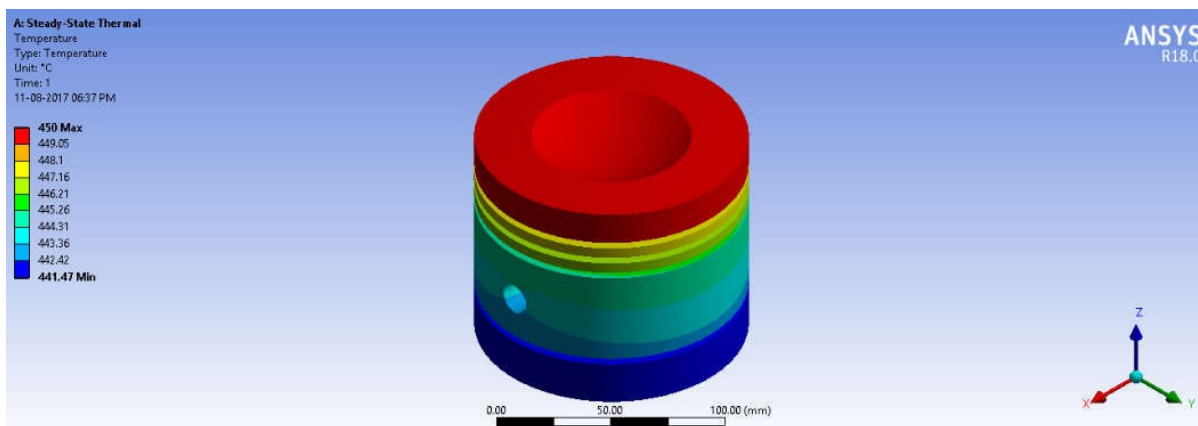

Figure 6 shows temperature variance piston with COPPOR

NON COATED PISTON MATERIAL AS BRONZE:

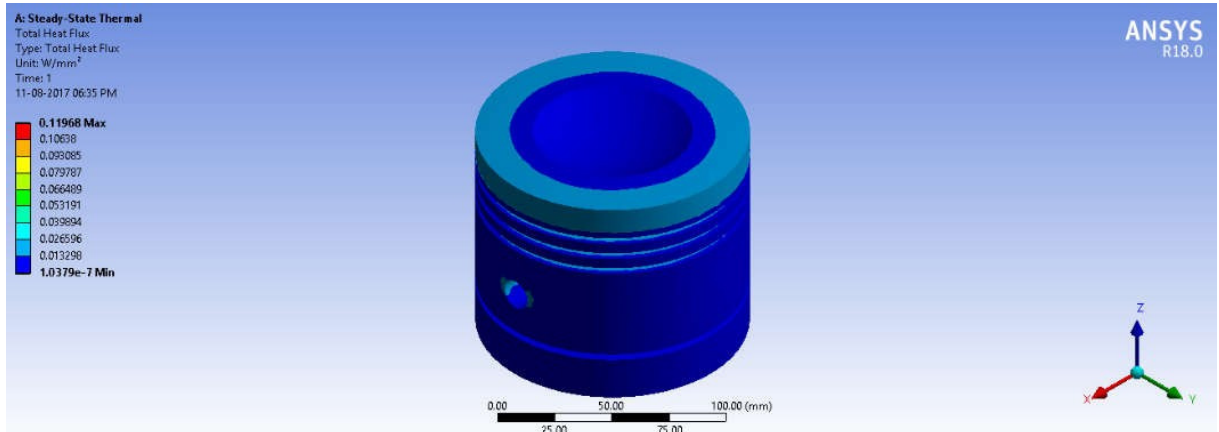

Figure 7 shows total heat flux piston with BRONZE

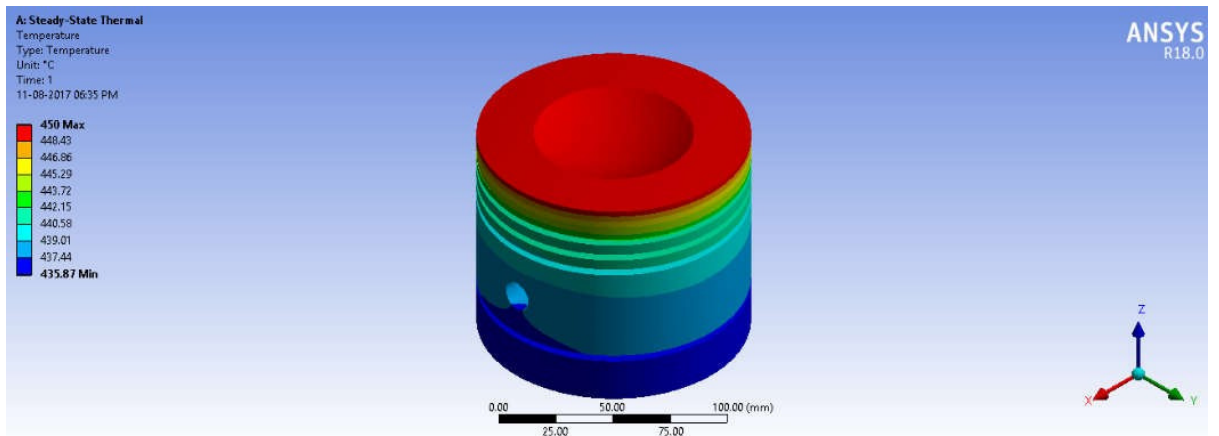

Figure 8 shows temperature variance piston with BRONZE

COATED PISTON MATERIAL AS COPPER:

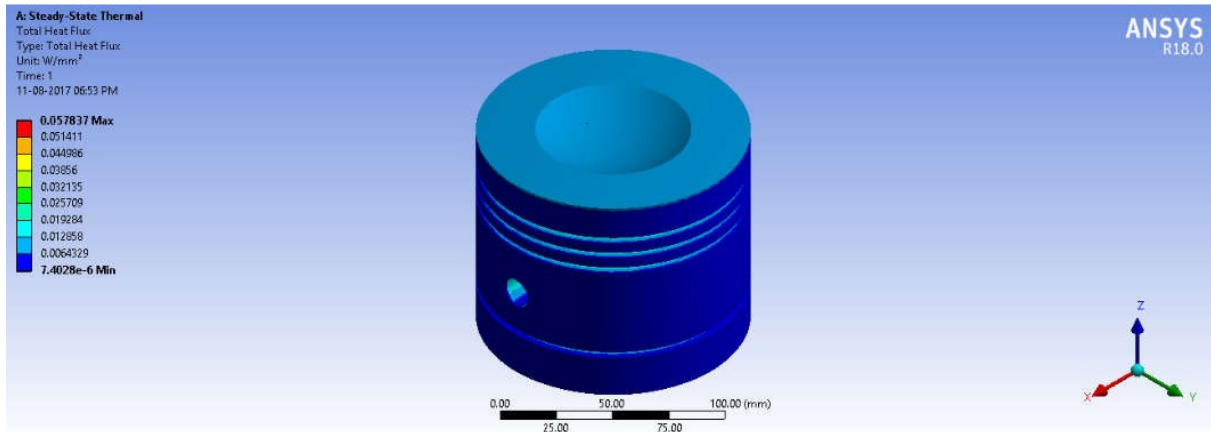

Figure 5 shows total heat flux piston with crown of COPPER

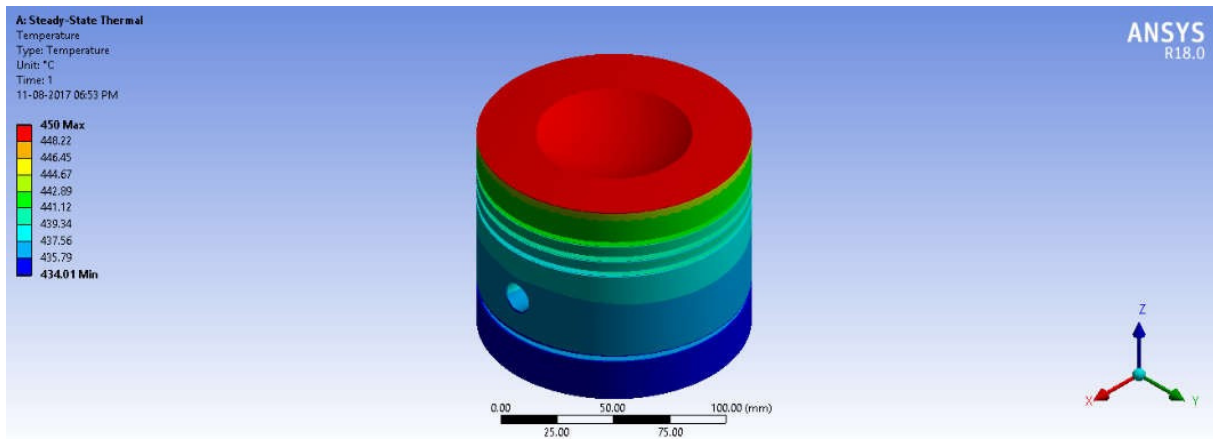

Figure 6 shows total temperature piston with crown of COPPER

COATED PISTON MATERIAL AS BRONZE:

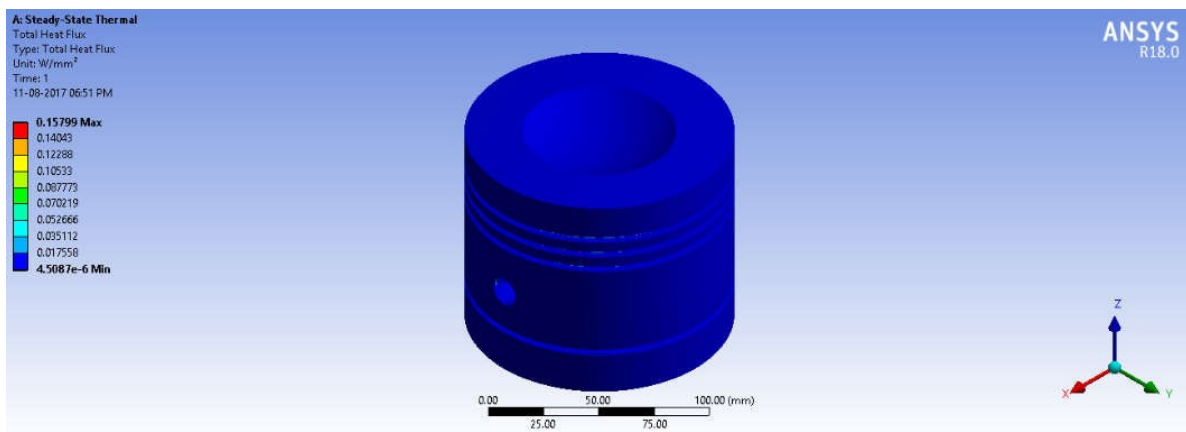

Figure 7 shows total heat flux piston with crown as BRONZE

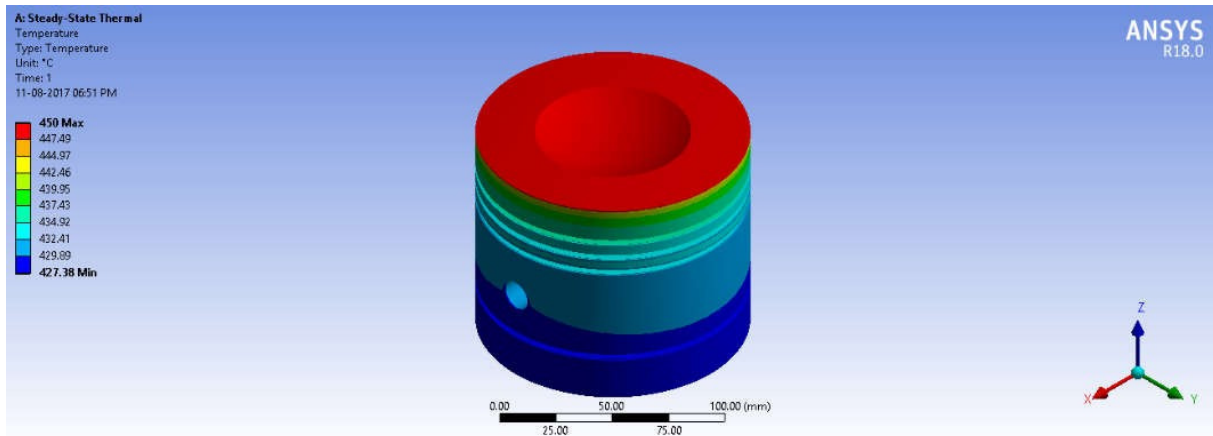
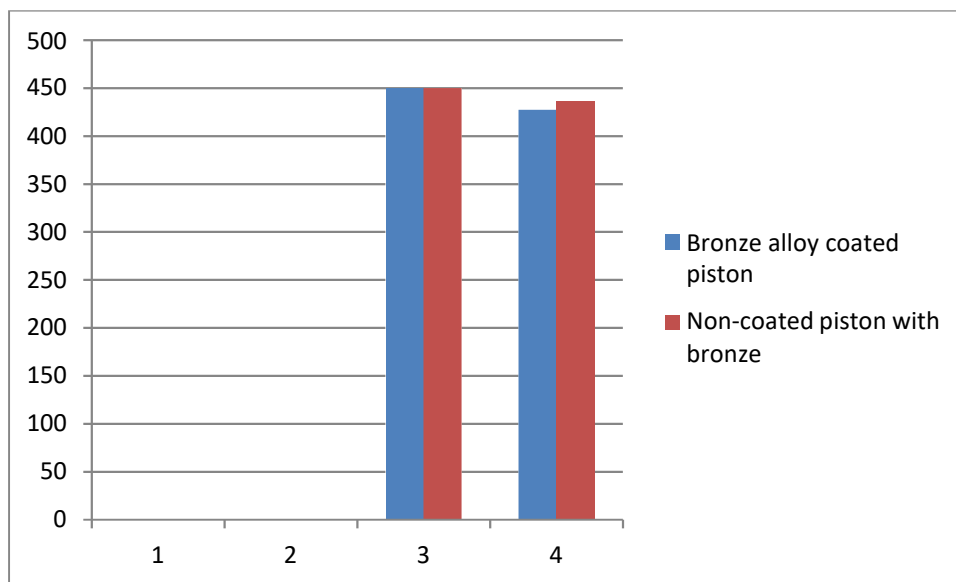

Figure 8 shows total heat flux piston with Crown as BRONZE.

**TABLE 4.1 COPPER ALLOY COATED PISTON AND NON -COATED PISTON ALLOY
MAXIMUM AND MINIMUM VALUES**

Materials	Heat flux		Temperature	
	Maximum	Minimum	Maximum	Minimum
Copper alloy coated piston	0.057837	7.0428e-6	450	434.01
Non-coated piston with copper alloy	0.049025	9.8654e-8	450	441.47



GRAPH 4.1 COPPER ALLOY COATED PISTON AND NON -COATED PISTON ALLOY MAXIMUM AND MINIMUM VARIATIONS

TABLE 4.2 BRONZE ALLOY COATED PISTON AND NON -COATED PISTON ALLOY MAXIMUM AND MINIMUM VALUES

Materials	Heat flux		Temperature	
	Maximum	Minimum	Maximum	Minimum
Bronze alloy coated piston	0.15799	4.5087e-6	450	427.38
Non-coated piston with bronze	0.11968	1.0379e-7	450	435.87

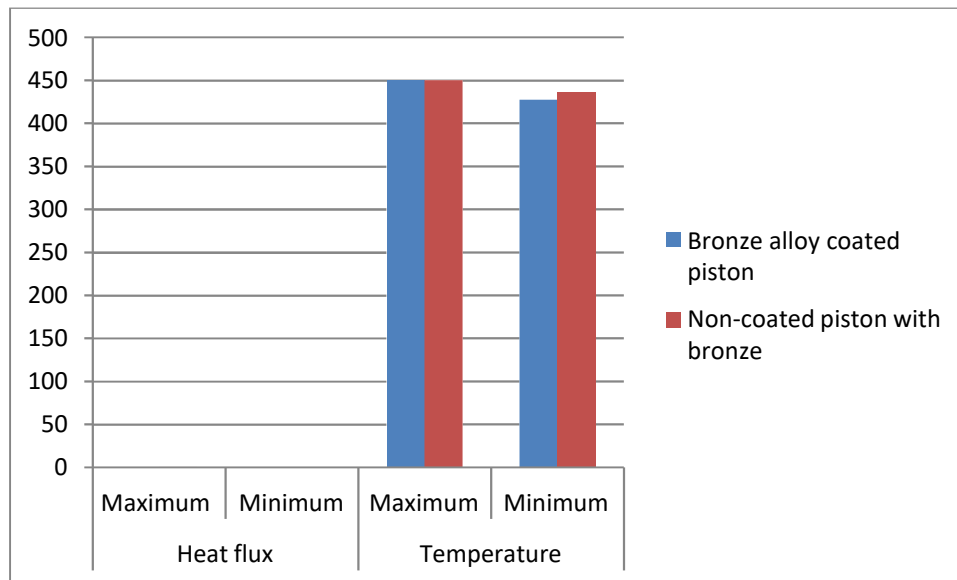

GRAPH 4.2 BRONZE ALLOY COATED PISTON AND NON -COATED PISTON ALLOY MAXIMUM AND MINIMUM VARIATIONS

TABLE 4.3 CAMPARISION OF COPPER AND BRONZE COATED AND NON COATED PISTION VALUES

Materials	Heat flux		Temperature	
	Maximum	Minimum	Maximum	Minimum
Copper alloy coated piston	0.057837	7.0428e-6	450	434.01
Non-coated piston with copper alloy	0.049025	9.8654e-8	450	441.47
Bronze alloy coated piston	0.15799	4.5087e-6	450	427.38
Non-coated piston with bronze	0.11968	1.0379e-7	450	435.87

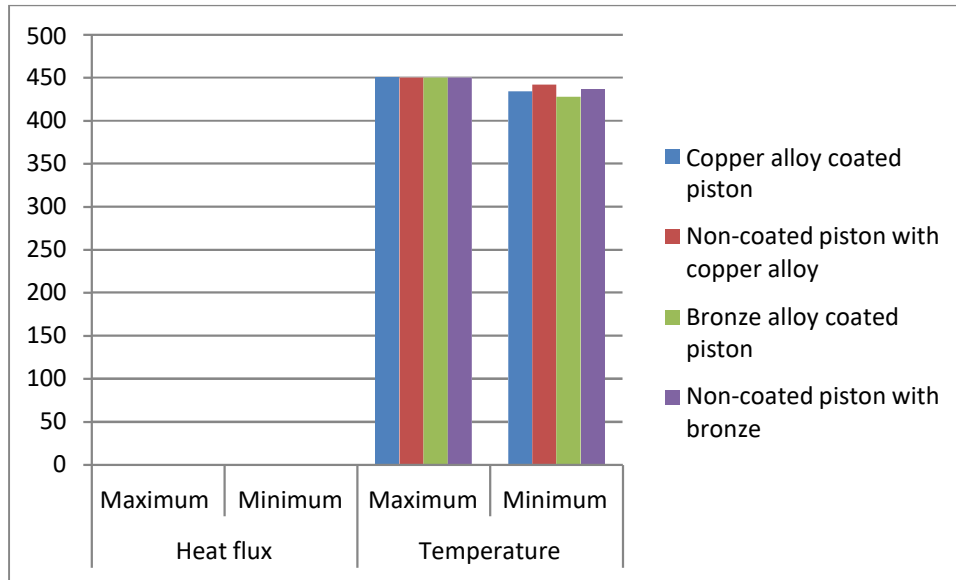

GRAPH 4.3 CAMPARISION OF COPPER AND BRONZE COATED AND NON COATED PISTION VARIATIONS

DISCUSSIONS:

It is observed that the Copper alloy which is coated has a better performance results as compared to coated Bronze alloy as well the non -coated Copper alloy is also having the better performance than the non-coatedBronze alloy so here we had observed that

COATED COPPER:

When a piston is coated with Copper and subject to heat flux the values obtained are as below

Heat flux : 0.057837max
: 7.0428e-6 min

When a piston is coated with Copper and subject to temperature the values obtained are as below

Temperature: 450⁰c max
: 434.01min

NON COATED COPPER:

When a piston is with non-coated with Copper and subject to heat flux the values obtained are as below

Heat flux : 0.049025max
: 9.8654e-8 min

When a piston is non-coated with Copper and subject to temperature the values obtained are as below

Temperature: 450⁰c max
:441.47 min

COATED BRONZE:

When a piston is coated with Bronze and subject to heat flux the values obtained are as below

Heat flux:0.15799Max
: 4.5087e-6 min

When a piston is coated with Bronze and subject to temperature the values obtained are as below

Temperature: 450⁰c max
: 427.38 min

NON COATED BRONZE:

When a piston is non-coated with Bronze and subject to heat flux the values obtained are as below

Heat flux: 0.11968 Max
: 1.0379e-7min

When a piston is non-coated with Bronze and subject to temperature the values obtained are as below

Temperature: 450⁰c max
: 435.87 min

Conclusion

The combustion, performance parameters and exhaust emissions were investigated experimentally in two different TBC LHRE diesel engines. The following were main conclusions drawn:

The specific fuel consumption is reduced by 20.58% and 11.60% at full load condition in Copper and Bronze alloy coated CI and YSZ coated CI engine respectively. ii. Heat flux increase by 26.13% and 13.23% in Copper and Bronze alloy coated CI and Copper and Bronze coated CI engine respectively. iii. The 10.50% and 5.26% higher peak cylinder pressure produce in Copper and Bronze alloy coated CI and YSZ coated CI engine respectively. The better combustion characterizes found in Copper and Bronze alloy coated CI engine. iv. Heat used in brake power of CI engines are better than the base engine. The heat lost in exhaust gas and heat lost in cooling

water was found more in CI engine than the base engine. Heat loss as an unaccounted was reduced by 55% in LHRE engine. After all heat balance sheet improved in CI engines. v. CO, HC, smoke density level reduced and NO_x level found higher in CI engine. vi. Noise level was found satisfactory in both type of CI engines. vii. Comparatively Copper and Bronze alloy coated CI engine found better combustion, performance and exhaust emissions.

REFERENCES

1. A Parlak and V Ayhan (2007), "The effects of using a piston with a thermal barrier layer in S.I engines". J. Energy Inst., Vol. 80, No. 5, pp. 223-228.
2. Barbezat G (2006), "Application of thermal spraying in the automobile industry", Surface and Coatings Technology, Vol.201, pp. 2028-2031.
3. Boehman A L, Vittal M, Borek J A, Marks D A and Bentz A P (1997), "The effects of thermal barrier coatings on diesel engine emissions", ASME ICE-Vol. 29-3, pp. 25-32.
4. Bose S (2007), "High temperature coatings", J. Appl. Thermal Engineering., Vol.9, No. 1, pp. 150-155.
5. Buyukkaya E, Engin T and Cerit M (2006), "Effects of thermal barrier coating on gas emissions and performance of a LHR engine with different injection timings and valve adjustments", Energy Conversion and Management, Vol. 47, pp. 1298-1310.
6. Chan S H (2001), "Performance and emissions characteristics of a partially insulated gasoline engine", International Journal of Thermal Sciences, 40, 255-251.
7. Chan S H and Khor K A (2000), "The effect of thermal barrier coated piston crown on engine characteristics", Journal of Materials Engineering and Performance, Vol. 9, No.1, pp. 103-109.
8. Chan S H and Khor K A (2000), "The effect of thermal barrier coated piston crown on engine characteristics", J. Mater Eng Perform. Vol. 9, No. 6, pp. 103-109.
9. Ekrem Buyukkaya, Tahsin Engin and Muhammet Cerit (2006), "Effects of thermal barrier coating on gas emissions and performance of a LHR engine with different injection timings and valve adjustments Thermodynamic Analysis", J. Energy Conversion and Management., Vol. 47, No. 6, pp. 1298-1310.
10. Felicia M Pitek and Carlos G Levi (2007), "Opportunities for TBCs in the ZrO₂- YO_{1.5}- TaO_{2.5} system", Surface & Coatings Technology., Vol. 31, No. 5, pp. 6044- 6050.
11. Vipul Jain, Dipesh Singh Parihar, Vaibhav Jain and Irfan H Mulla. Performance of Exhaust Gas Recirculation (EGR) System on Diesel Engine. International Journal of Engineering

Research and Applications (IJERA) ISSN: 2248-9622 Vol. 3, Issue 4, Jul-Aug 2013, pp.1287-1297 .

12. Avinash Kumar Agarwal, Shravan Kumar Singh, Shailendra Sinha and Mritunjay Kumar Shukla. Effect of EGR on the exhaust gas temperature and exhaust opacity in compression ignition engines. Sadhana Vol. 29, Part 3, June 2004, pp. 275–284.

13. Sang-Ki Park, Kap-Seung Choi, Hak-Min Wang, Hyung-Man Kim and Dae-Hee Lee Tae-Jin Kim and Joon Lee. Heat Exchange Efficiency Characteristics of EGR Cooler with Stack-Type or Shell & Tube-Type. SAE International 2007-01-3446.

14. Pratibhu Roy, Indranil Sinha, Bijan Kumar Mandal, Achin Kumar Chowdhari. The effect of Exhaust Gas Recirculation (EGR) in Compression Ignition Engine. International Journal of Emerging Technology and Advanced Engineering Volume 3, Special Issue 3: ICERTSD 2013, Feb 2013, pages 106-111 An ISO 9001:2008 certified Int. Journal, ISSN 2250-2459.

15. Amr Ibrahim and Saiful Bari. An Investigation on using EGR on natural gas SI Engine. International Conference on Mechanical Engineering 2007(ICME2007) 29- 31 December 2007.

16. P. V. Walke, Dr. N. V. Deshpande, R.G. Bodkhe. Impact of Exhaust Gas Recirculation on the Performances of Diesel Engine. Proceedings of the World Congress on Engineering 2008 Vol II WCE 2008, July 2 - 4, 2008, London, U.K.

17. Joseph R. Griffin, Chris Ganseman and Chris Baerts, Nelson Burkholder, Stephen M. Geyer and Doug Smith. Cooled

Design Development and Analysis of Exhaust Gas Recirculation System for CNG Fuelled SI Engine DOI: 10.9790/1684-1316273

18. Lubomír Miklánek, Vojtěch Klír, Miloslav Emrich and Luděk Pohořelský. Thermal Balance Method for EGR Rate Determination Usable for Real Engine with Uncooled EGR System. SAE International 2009-01-1114.

19. Orian Welling and Nick Collings. UEGO Based Measurement of EGR Rate and Residual Gas Fraction. SAE International doi:10.4271/2011-01-1289.

20. Jaffar Hussain, K. Palaniradja, N. Alagumurthi, R. Manimaran. Effect of Exhaust Gas Recirculation (EGR) on Performance and Emission characteristics of a Three Cylinder Direct Injection Compression Ignition Engine. Alexandria Engineering Journal (2012) 51, 241-247

21. Chan S H and Khor K A (2000), “The effect of thermal barrier coated piston crown on engine characteristics”, J. Mater Eng Perform. Vol. 9, No. 6, pp. 103-109.