

DESIGN AND FABRICATION OF AN AUTOMATED WASTE SEGREGATOR SYSTEM

¹Dr. S. Venkateswarlu, ²Darzi Niyaz Ahammad, ³Tanguturi Chand Basha, ⁴Bathula Ramesh Babu, ⁵Chakali Surendra, ⁶Besta Thirumalesh

¹Professor, Department of Mechanical Engineering, G. Pullaiah College of Engineering & Technology, Kurnool, India.

^{2,3,4,5,6}Engineering Student Department of Mechanical Engineering, G. Pullaiah College of Engineering & Technology, Kurnool, India.

Abstract: Waste Management and segregation is a much-needed process in metro cities and urban areas due to the spreading of diseases. It is estimated that India produces 60 million tons of municipal solid waste annually at present. Waste lying littered in the surrounding, dumped on open lands, becomes a major problem for various types of disease-causing bacteria and viruses hence, segregation, transport, handling, and disposal of waste must be managed properly to minimize the risks to the public and environment. When mixed dry and wet waste breaks down in the lowland, it creates nasty greenhouse gases. Segregation makes it attainable to utilize and recycle waste effectively. This waste segregator system can easily segregate waste. When waste is thrown in the pipe, the IR sensor will sense the waste. Waste is divided into three categories namely Wet, Dry, and Metallic. Another sensor will sense the garbage category. As per the algorithm used, if the waste is metallic then the mechanism will bring the metal collecting bin below the pipe and with the help of a servo motor the waste will fall into the metal bin. Similarly, the process will repeat if wet waste is sensed. If the sensor doesn't activate both the sensor category then the waste will be considered to be a dry waste segregation system for household use, so that it can be sent directly for processing. It is designed to sort the refuse into metallic waste, wet waste, and dry waste. The AWS employs a parallel resonant impedance sensing mechanism to identify metallic items, and capacitive sensors to distinguish between wet and dry waste. Experimental results show that the segregation of waste into metallic, wet, and dry waste has been successfully implemented using AWS.
Keywords: Dry, Wet, Metal, Sensors, Segregation.

1. INTRODUCTION

In India, about 60 million tonnes of waste is generated every year. Ten million tonnes of garbage is generated in metropolitan cities. The landfills of most of these cities are overflowing with no space for fresh garbage waste. The philosophy of “waste management hierarchy” has been adopted by most nations as the step for developing municipal solid waste (MSW) management strategies. According to a sanitation survey called the Ministry of urban development under the Swachh Bharat mission, it was found that about 50% of people in India face the problem of improper waste collection and management. According to the Centre of Science and Environment, innovative disposal and recycling methods must be introduced instead of the “Swachh Survekshan-2016” conducted. Thus, we have proposed a cost-effective Automatic waste segregator that categorizes the waste as plastic, metallic, or organic. The monitoring system helps to monitor the waste collection process. The common method of waste disposal is unplanned and uncontrolled dumping at landfill areas. This method is hazardous to human health, and plant, and animal life. When the waste is segregated into basic streams such as plastic, metallic and organic, the waste has a higher potential of recovery, and then, recycled and reused “Automatic waste segregator and monitoring system” for proper management of waste. The organic waste is converted either into compost or methane gas

or both Compost can replace the demand for chemical fertilizers, and biogas can be used as a source of energy. The metal waste could be reused or recycled. Even if there is large-scale industrial waste segregation present, it is always feasible to separate the waste at the source itself. The hazard for waste workers is reduced. Also, the separated waste could be directly sent to the recycling and processing plant instead of sending it to the segregation plant and then to the recycling plant.

2. METHODOLOGY

A waste management system is the strategy an organization uses to dispose of, reduce, reuse, and prevent waste. Possible waste disposal methods are recycling, composting, incineration, landfills, bioremediation, waste to energy, and waste minimization. Waste is divided into three categories namely Wet, Dry, and Metallic. Another sensor will sense the garbage category. As per the algorithm used, if the waste is metallic then the mechanism will bring the metal collecting bin below the pipe and with the help of a servo motor the waste will fall into the metal bin.

3. DESIGN DRAWINGS FROM SOLID WORKS

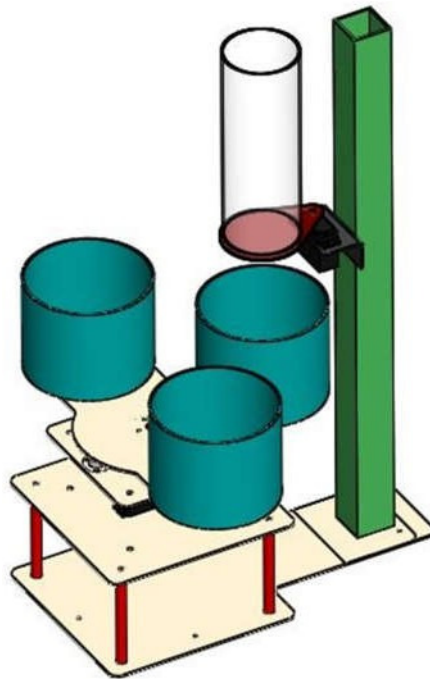

FIG. 3.1: 3D VIEW OF AUTOMATIC WASTE SEGREGATION SYSTEM.

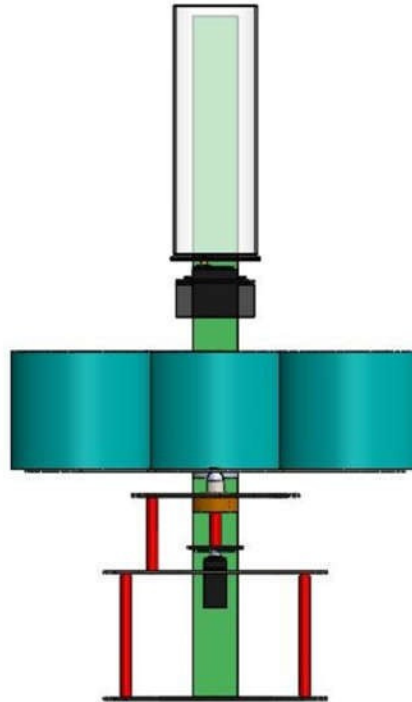

FIG 3.2: FRONT VIEW OF AUTOMATIC WASTE SEGREGATION SYSTEM

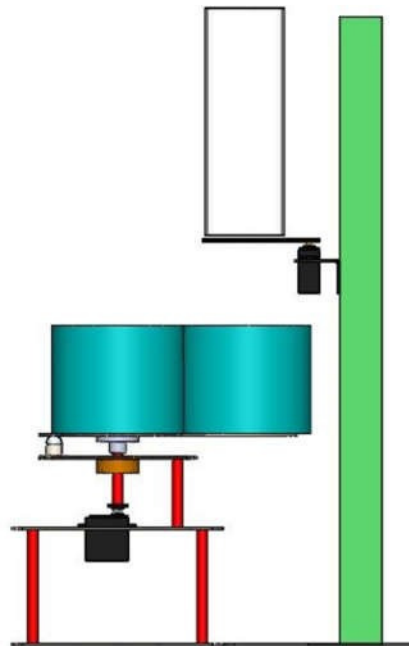

FIG 3.3: SIDE VIEW OF AUTOMATIC WASTE SEGREGATION SYSTEM

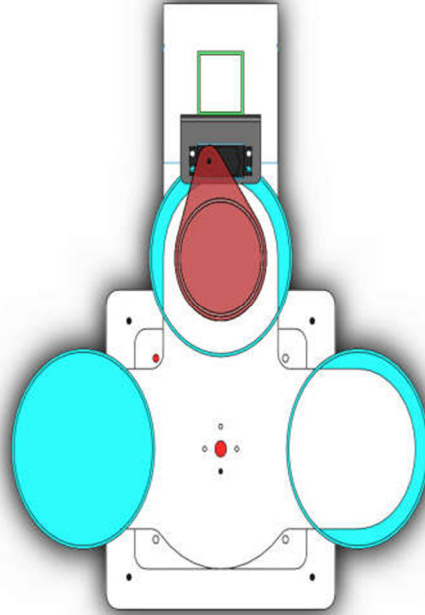

FIG 3.4: TOP VIEW OF AUTOMATIC WASTE SEGREGATION SYSTEM

4. COMPONENTS

1. Servo Motor (MG996R)
2. Base Plate
3. Container
4. Round Plate
5. Rod Spacer
6. Supporting Frame
7. Mounts
8. Joints & Screws
9. Coupler

5. PARTS DESCRIPTION

1.SERVO MOTOR (MG996R)

- a) Weight: 55g
- b) Dimension: 40.7×19.7×42.9mm
- c) Stall torque: 9.4kg/cm (4.8v); 11kg/cm (6.0v)
- d) Operating speed: 0.19sec/60degree (4.8v); 0.15sec/60degree (6.0v)
- e) Operating voltage: 4.8 ~ 6.6V

Gear Type: Metal gear

- a) Dead band width: 1us
- b) Wire length: 32cm

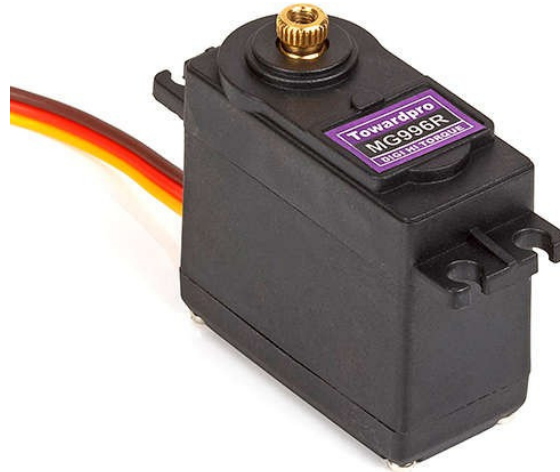

Features:

- a) Gear Type: Metal gear
- b) Servo Plug: JR (Fits JR and Futaba)
- c) Servo arms & screws included, and fit with Futaba servo arm
- d) It's a universal "S" type connector that fits most receivers, including Futaba, JR, Hitec, GWS, Cirrus, Blue Bird, Blue Arrow, Corona, Berg, and Spektrum.
- e) CE & RoHS approved
- f) We have upgraded our servo gear set and shaft to aluminum 6061-T6. It is stronger and lighter than copper.

2. Round Plate:

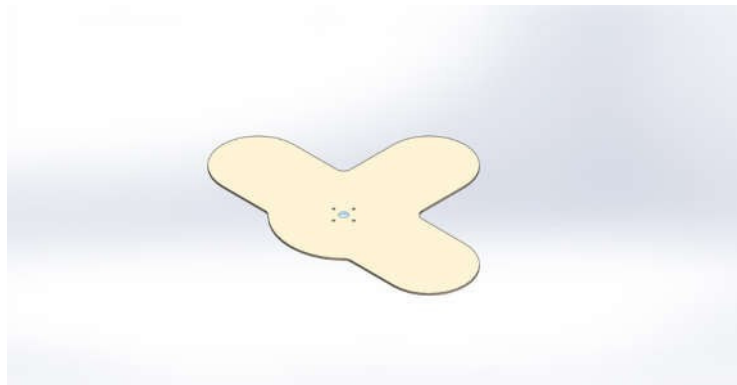

Round Plate is used to hold the container and rotate accordingly.

3. Container:

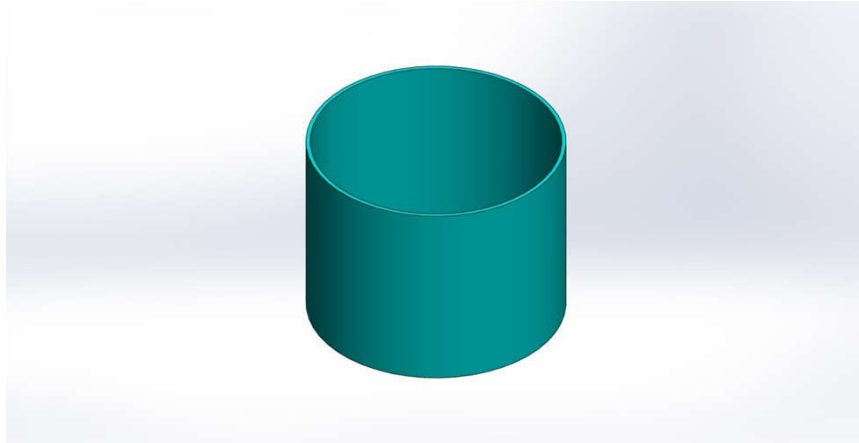

The container is used to contain/hold the different types of waste.

4. Supporting Frame (Mild Steel):

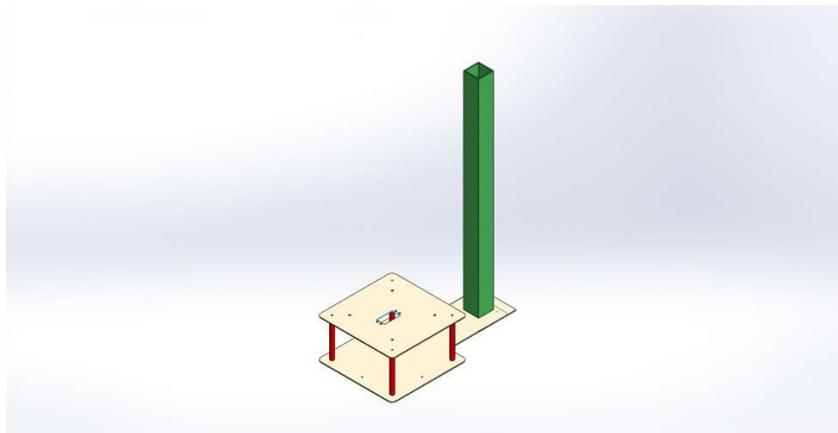

A frame is often a structural system that supports other components of physical construction and/or a steel frame that limits the construction's extent. An A-frame is a basic structure designed to bear a load in a lightweight economical manner. The simplest form of an A-frame is two similarly sized beams, arranged at an angle of 45 degrees or less, attached at the top, like an uppercase letter 'A'. These materials are often wooden or steel beams attached at the top by rope, welding, gluing, or riveting.

5. Base Plate and Rod Spacer:

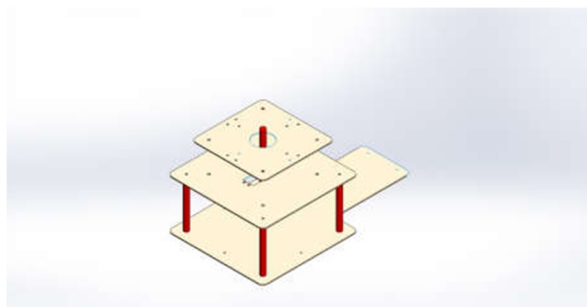

6. WORKING

1. Drop the waste into the pipe.
2. IR sensor will sense the waste and it will rest on the bottom plate.
3. Now the sensor on the plate will sense the waste as in 3 categories - Metallic or wet.
4. Now the algorithm is so made that if the waste is metallic then the mechanism will bring the metal collecting bin below the pipe and the servo will let the waste fall into the bin.
5. Similarly, the process will be repeated for the wet test.
6. If both the sensor doesn't activate then the waste will be detected as dry waste.

7. RESULTS

“Automatic Waste Segregation System” sorts wastes into three different categories, namely metal, plastic, and wet (organic) waste. Wet waste refers to organic waste such as vegetable peels, leftover food, etc. Separating our waste is essential as the amount of waste being generated today causes an immense problem.

Here, we have tested the household wastes which are generated in every home today and we have come up with the following result.

When exposed to our automatic waste segregator and monitoring system. The proposed system would be able to monitor the solid waste collection process and management of the overall collection process.

It would provide in-time solid waste collection. The technologies which are used in the proposed system are good enough to ensure the practical and perfect for solid waste collection process monitoring and management for a green environment.

8. CONCLUSIONS

This paper enhances the cleanliness of smart cities through the practical application of Automatic waste management and segregation system using automation with urbanization and increasing population, disposal of waste is a major concern. This proposed system is an effective waste segregation system that has no human intervention or interference to separate dry and wet waste. It provides timely collection and disposal. The proposed system can be deployed on a domestic scale in a household or a large scale in public places.

FUTURE SCOPE

- Inlet selection can be incorporated with a crusher mechanism to reduce the size of incoming waste.
- Provisions can be made for on spot decomposition of wet waste.
- Solar panels can be used for power supply.

REFERENCES

1. Padmakshi Venkateshwara Rao, Pathan Mohammed Abdul Azeez IoT-based waste management for smart cities International conference on computer communication and information (ICCCI), Coimbatore, India, Jan22-24,2020.
2. Nikolaos Baras, Dimitris Ziouzos A cloud-based smart recycling bin for in-house waste classification in the 2nd International Conference on Electrical, Communication and Computer Engineering, Istanbul Turkey June 12-13 2020.
3. Shashank Shetty, Saket Salvi "SAF-Sutra: A prototype of Remote Smart Waste Segregation and Garbage Level Monitoring System" International Conference Communication and Signal Processing, India, July 28-30,2020.
4. Claude-Noel Tamakaloe, Dr. Elena V. Rosca "Smart System and the Internet of Things (IoT) For Waste Management" Bioengineering/Electrical and Electronic Engineering Dep. Ashesi University Accra, Ghana.
5. Rania Rizki Arinta, Dominikus Boli Watomakin Improve Smart Waste Management to Preserve Tourist Attraction Yogyakarta in IoT Environment International Conference on Smart Technology and Applications (ICoSTA), 2020.
6. Chetna Kaushal, Anshu Singla "Architecture for garbage Monitoring System using Integrated Technology"15 September 2020.
7. M. Al-Maaded, N. K. Madi, Ramazan Kahraman, A. Hodzic, N. G. Ozerkan, An Overview of Solid Waste Management and Plastic Recycling in Qatar, Springer Journal of Polymers and the Environment, March 2012, Vol. 20 (1), pp 186-194.
8. Raghmani Singh, C. Dey, M. Solid waste management of Municipality of Thoubal, Manipur- a case study of Green Technology and Environmental Conservation,2011 International Conference, Chennai.
9. Vikrant Bhor, Smart Management System for garbage in International Journal of Engineering Research and Technology March-2015.
10. Kumar, N. S., Vuayalakshmi, B., Prarthana, R. J., & Shankar, A. (2016). IoT smart garbage alert system using Arduino UNO. 2016 IEEE Region 10 Conference (TENCON).